



VF series direct acting solenoid valves are designed to be mounted on any type of pneumatic actuator or cylinder with the advantage of merging the actuator and its control valve in a single product. It has a 1/8" air inlet and 1/8" and 1/4" feeding screw. The valve is equipped with a manual operation screw to carry out the operation tests and can accommodate coils with different voltages.

Les électrovannes à commande directe de la série VF ont été conçues pour être montées sur tout type d'actionneur ou de vérin pneumatique avec l'avantage d'incorporer l'actionneur et la vanne de commande en un seul produit.

Il a une entrée d'air de 1/8" et vis d'alimentation 1/8" et 1/4". La vanne est équipée d'une vis d'entraînement manuelle pour effectuer les tests de fonctionnement et peut accueillir des bobines avec différentes tensions.

Le elettrovalvole a comando diretto della serie VF sono state concepite per essere montate su qualsiasi tipo di attuatore o cilindro pneumatico con il vantaggio di incorporare attuatore e la sua valvola di controllo in un unico prodotto.

L'ingresso aria è da 1/8" mentre le viti di alimentazione possono essere da G1/8 o da G1/4. La valvola è dotata di vite per azionamento manuale per effettuare i test di funzionamento e può ospitare bobine con diversi voltaggi.

TECHNICAL DATA / **DONNÉES TECHNIQUES** / DATI TECNICI

Fluid / Fluide / Fluido	Lubricated or non lubricated air / Air lubrifié ou non / Aria con o senza lubrificazione
Type / Type / Tipo	3/2
Max operating pressure / Pression max d'utilisation / Pressione massima di esercizio	10 bar
Max working temperature / Température max d'utilisation / Temperatura max di esercizio	-10°C / + 50°C
Flow rate to 6 bar and Δp 1 bar / Débit à 6 bar et Δp 1 bar / Portata a 6 bar e Δp 1 bar	35 NI/min
Nominal orifice / Diamètre nominal / Diametro nominale	1,2 mm
Tension tolerance / Tolérance de tension / Tolleranza di tensione	-10% - +15%
Response time / Temps de réponse / Tempo di risposta	10 ms
Duty cycle / Temps d'enclenchement / Inserimento	ED 100%
Rated power consumption / Consommation / Consumo a regime	DC: 3W - AC: 5VA
Coils tension / Tension bobine / Tensione bobine	24 VDC - 24 VAC - 110 VAC - 220 VAC 50/60Hz
Protection / Protection / Protezione	IP 65

ORDERING CODE / **CODIFICATION** / CHIAVE DI CODIFICA

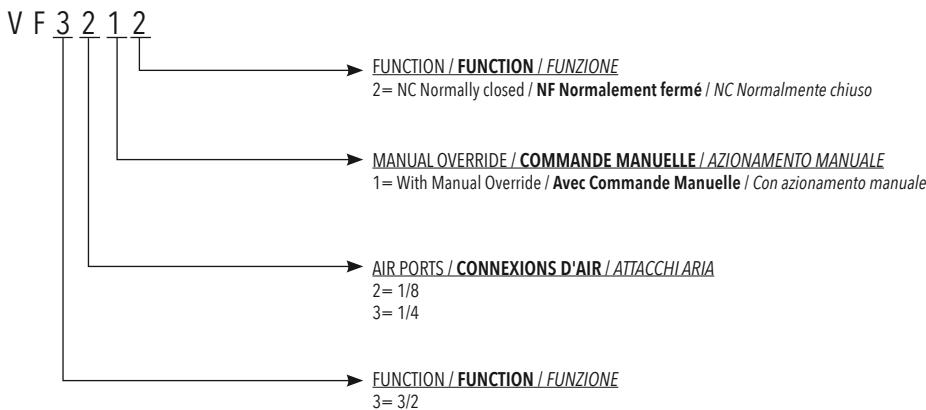

ASSEMBLY SYSTEM / **SYSTEME DE MONTAGE** / SISTEMA DI MONTAGGIO



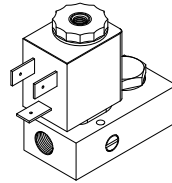
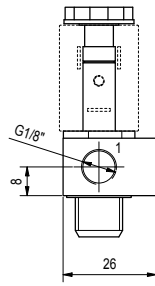
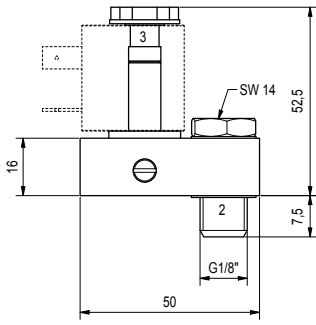

1/8 3/2 NC Normally closed
1/8 3/2 NF Normalement fermé
 1/8 3/2 NC Normalmente chiuso

CODE
VF3212

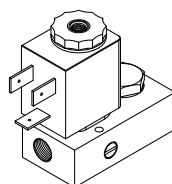
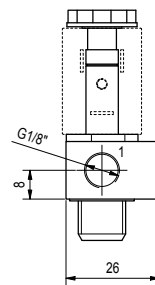
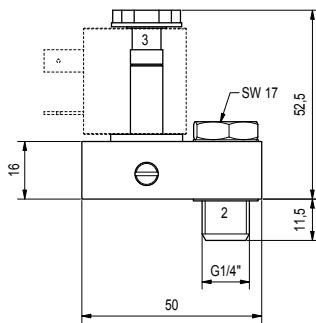
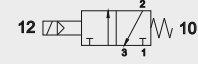

1/4 3/2 NC Normally closed
1/4 3/2 NF Normalement fermé
 1/4 3/2 NC Normalmente chiuso

CODE
VF3312

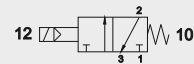

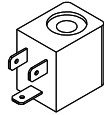
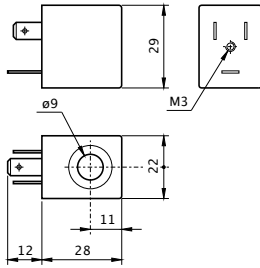

COILS
BOBINE
 BOBINE

POWER / ABSORPTION / ASSORBIMENTO

CODE	Tension Tension Tensione	Rated Résistance a regime	Inrush De sortie di spunto
BO4011012	12 VDC	3W	
BO4011024	24 VDC	3W	
BO4012024	24 VAC	5VA	7,5VA
BO4012110	110 VAC	5VA	7,5VA
BO4012220	220 VAC	5VA	7,5VA

TECHNICAL SPECIFICATIONS
CARACTERISTIQUES TECHNIQUES
 CARATTERISTICHE TECNICHE

Tension tolerance / Tolérance / Tolleranza di tensione	+10%
Protection with connector / Protection avec connecteur / Protezione con connettore	IP65
Max working temperature / Température max d'utilisation / Temperatura max di esercizio	+ 50°C
Duty cycle / Temps d'enclenchement / Inserimento	ED 100%

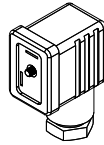
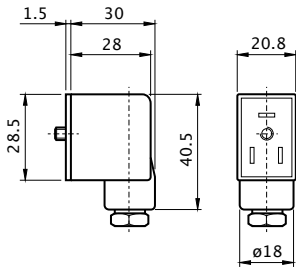

CONNECTORS
CONNECTEUR
 CONNETTORI

CODE	DES.
AR40696	STANDARD
VX0014	LED 24V
VX0015	LED 110V
VX0016	LED 220V
VX0017	LED+VDR 24V
VX0018	LED+VDR 110V
VX0019	LED+VDR 220V

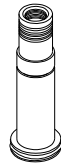
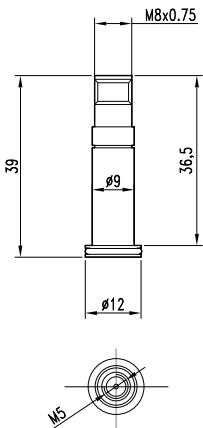

SOLENOID PILOT
ELECTROPILOTE
 ELETTROPILOTA

CODE
EP43603

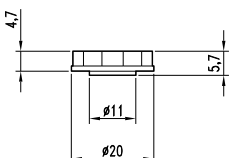
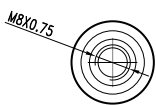

NUT
ECROU
 DADO

CODE
DA42937