



DATI TECNICI / TECHNICAL DATA

Fluido / Fluid	Aria / Air		
Pressione Max / Maximum pressure	15 bar		
Temperatura / Temperature	-10 / +50° C		
Portata a 6 bar con Δp 1 bar / 6bar flow rate with Δp 1bar	1=800 NI/min	2=2100NI/min	3=3500NI/min
Viti per fissaggio / Wall clamping screws	1=M4X14	2=M5X18	3=M6X20
Capacità tazza / Bowl capacity	1=22cm3	2=46cm3	3=89,5cm3

PRODOTTI STANDARD / STANDARD PRODUCTS

codice code	taglia size	filetto thread	filtrazione filtration	portata flow rate	regolazione regulation
XM122311	1	1/4	20µm	800NI/min	0 - 8bar
XM132311	1	3/8	20µm	800NI/min	0 - 8bar
XM232311	2	3/8	20µm	2100NI/min	0 - 8bar
XM242311	2	1/2	20µm	2100NI/min	0 - 8bar
XM352311	3	3/4	20µm	3500NI/min	0 - 8bar
XM362311	3	1"	20µm	3500NI/min	0 - 8bar

CHIAVE DI CODIFICA / ORDERING CODE

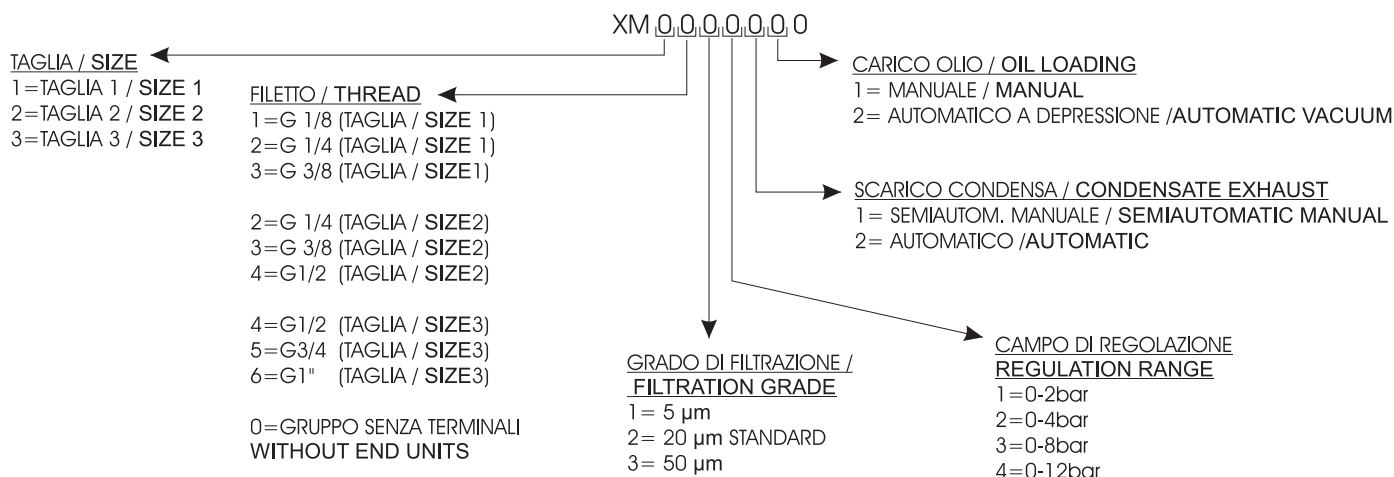

DIMENSIONI / DIMENSIONS

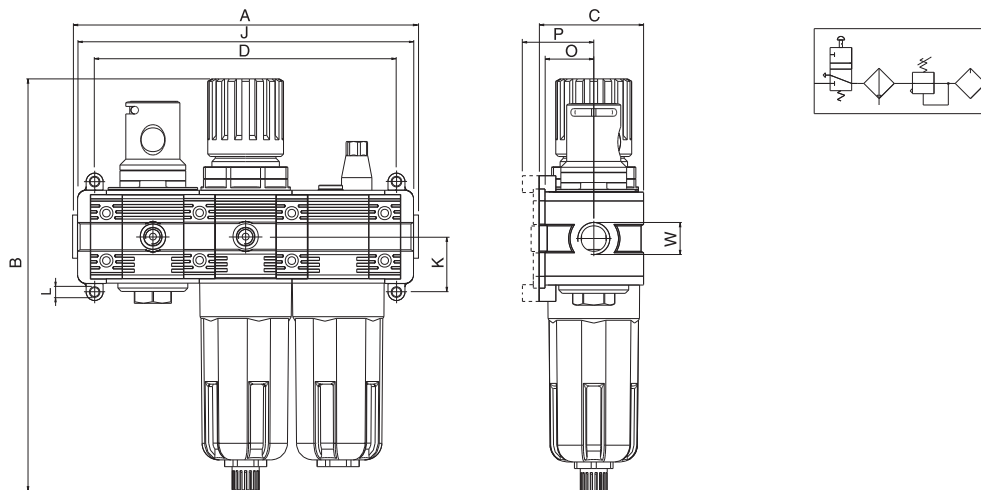

	A	B	C	D	W	J	K	L	O	P
taglia 1 / size 1	115	198	45	118,5	1/8 - 1/4 - 3/8	97	26	M4	48,5	55
taglia 2 / size 2	144	244,5	59	199	1/4 - 3/8 - 1/2	124	32,5	M5	62,5	69
taglia 3 / size 3	165	273	70	236	1/2 - 3/4 - 1	144	38	M6	73,5	80

VALVOLA + FILTROREGOLATORE + LUBRIFICATORE (V+FR+L)  
 VALVE+FILTERREGULATOR+LUBRICATOR (V+FR+L)