



DATI TECNICI / TECHNICAL DATA

Fluido / Fluid	Aria / Air
Pressione Max / Maximum pressure	15 bar
Temperatura / Temperature	-10 / +50° C
Campo di regolazione / Regulation range	0-2bar 0-4bar 0-8bar standard 0-12bar
Grado di filtrazione / Filtration grade	5µm - 20µm standard - 50µm
Portata a 6 bar con Δp 1bar / 6bar flow rate with Δp 1bar	280 Nl/min
Attacco manometro / Manometer fastening	1/8
Capacità tazza / Bowl capacity	17,5cm ³

CHIAVE DI CODIFICA / ORDERING CODE

XT0,0,0,0,1 1

- CAMPO DI REGOLAZIONE
REGULATION RANGE
1=0-2bar
2=0-4bar
3=0-8bar STANDARD
4=0-12bar
- GRADO DI FILTRAZIONE /
FILTRATION GRADE
1= 5 µm
2= 20 µm STANDARD
3= 50 µm
- FILETTO / THREAD
1=G 1/8 (TAGLIA 1)
2=G 1/4 (TAGLIA 1)

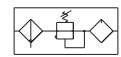
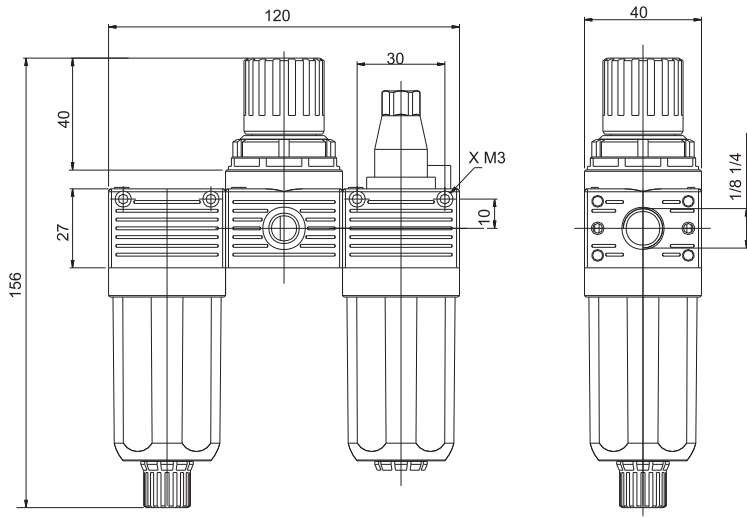

Trattamento aria / Air treatment
 FILTRO+REGOLATORE+LUBRIFICATORE (F+R+L)
 FILTER+REGULATOR+LUBRICATOR (F+R+L)