



DATI TECNICI / TECHNICAL DATA

Fluido / Fluid	Aria / Air		
Pressione Max / Maximum pressure	15 bar		
Temperatura / Temperature	-10 / +50° C		
Grado di filtrazione / Filtration grade	5 - 20 - 50µm		
Portata a 6 bar con Δp 1 bar / 6bar flow rate with Δp 1bar	1=1350 NI/min	2=3200NI/min	3=5000NI/min
Capacità tazza / Bowl capacity	1=22cm3	2=46cm3	3=89,5cm3
Viti per fissaggio / Wall clamping screws	1=M4X14	2=M5X18	3=M6X20

PRODOTTI STANDARD / STANDARD PRODUCTS

codice code	taglia size	filetto thread	filtrazione filtration	portata flow rate
XO122011	1	1/4	20µm	1350NI/min
XO132011	1	3/8	20µm	1350NI/min
XO232011	2	3/8	20µm	3200NI/min
XO242011	2	1/2	20µm	3200NI/min
XO352011	3	3/4	20µm	5000NI/min
XO362011	3	1"	20µm	5000NI/min

S/M: Semiautomatico Manuale / Semi automatic Manual
 Δ: Automatico / Automatic

CHIAVE DI CODIFICA / ORDERING CODE

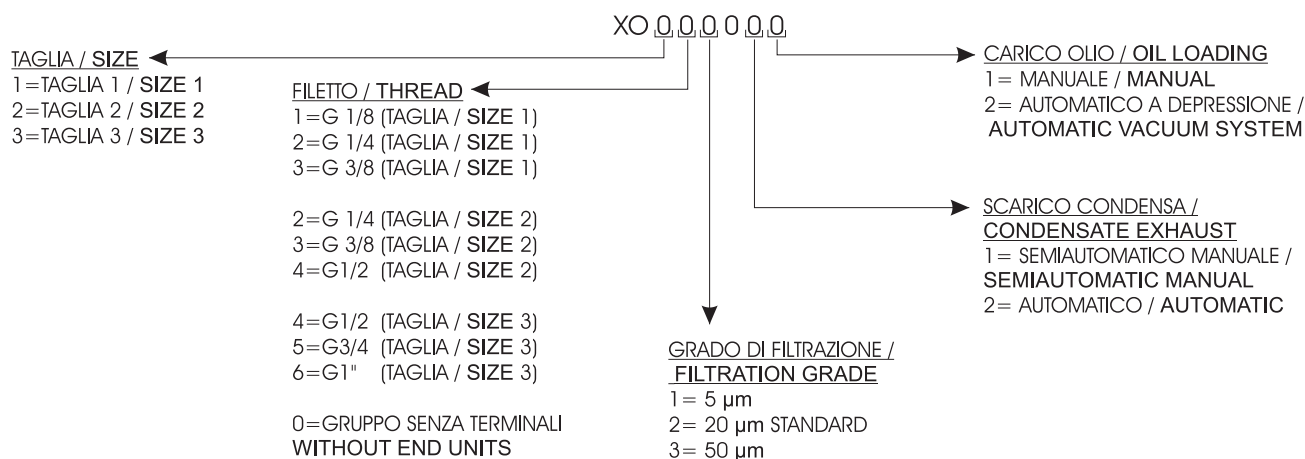

DIMENSIONI / DIMENSIONS

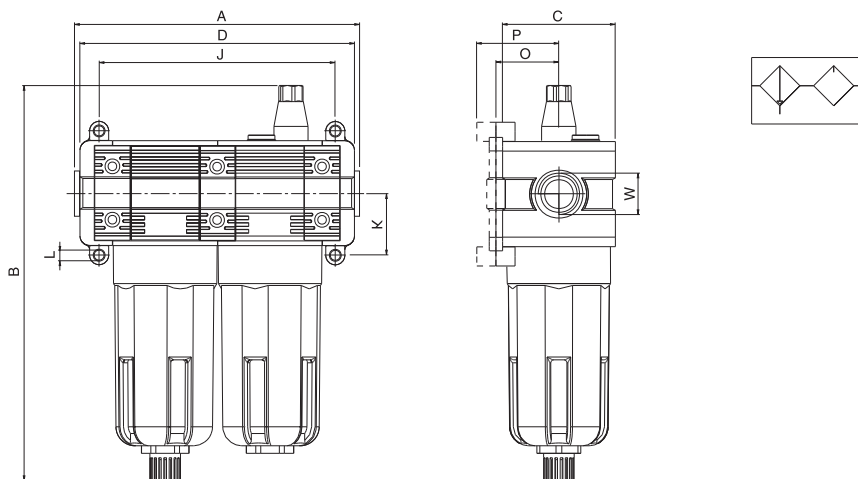

	A	B	C	D	W	J	K	L	O	P
taglia 1 / size 1	115	175	45	118,5	1/8 - 1/4 - 3/8	97	26	M4	48,5	55
taglia 2 / size 2	144	207,5	59	144	1/4 - 3/8 - 1/2	124	32,5	M5	62,5	69
taglia 3 / size 3	165	226,5	70	171	1/2 - 3/4 - 1	144	38	M6	73,5	80