



VQ indirect electrovalves, are particularly suitable to control water, air, inert gas, steam and for all fluids in general (not aggressive).
 The extremely compact brass body, gives to them the possibility to be used in very small places.
 They're available in different versions as 2/2, 3/2 NC and NO and with NBR, Viton or EPDM seals.

Les électrovannes de la série VQ à commande indirecte sont particulièrement appropriées pour contrôler l'eau, l'air, le gaz inerte, la vapeur d'eau et tous les fluides généralement non agressifs. Le corps en laiton est compact et permet une utilisation dans des espaces confinés. Plusieurs versions sont disponibles comme 2/2, 3/2 NF et NO et joints en NBR, Viton ou EPDM.

Le elettrovalvole della serie VQ a comando indiretto sono particolarmente indicate per il controllo di acqua, aria, gas inerti, vapore e in generale di fluidi non aggressivi. Il corpo in ottone estremamente compatto ne permettono l'utilizzo in spazi molto ristretti. Sono disponibili diverse versioni tra cui 2/2 e 3/2 NC e NA e guarnizioni in NBR, Viton e EPDM.

ORDERING CODE / CODIFICATION / CHIAVE DI CODIFICA

V Q I 1 4 2 2 C 1 0 N 0

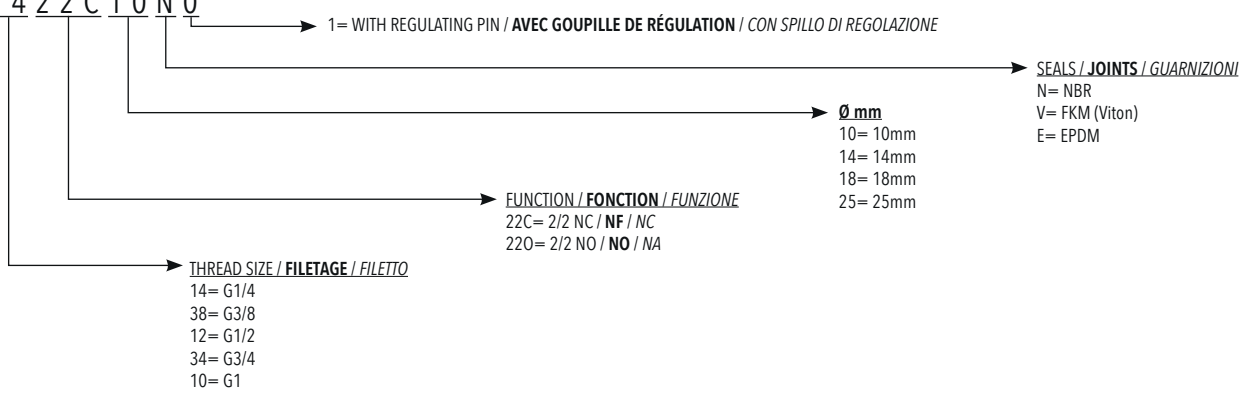

TECHNICAL CHARACTERISTICS / CARACTÉRISTIQUES TECHNIQUES / CARATTERISTICHE TECNICHE

Max. allowable pressure / Pression de service max. / Pressione massima ammissibile	25 bar		
Temperature range / Température d'utilisation / Temperatura di utilizzo	NBR	-10°C / +90°C	Air, inert gas, water max 75 °C, mineral oils, gas oil, fuel oils Air, gas neutres, eau max. 75°C, huiles minerales, diesel, mazout <i>Aria, gas inerti, acqua max 75 °C, oli minerali, gasolio, oli combustibili</i>
	FKM	-10°C / +140°C	Mineral oils, gasoline, gas oil, fuel oils Huiles minerales, essence, mazout <i>Oli minerali, benzina, oli combustibili</i>
	EPDM	-10°C / +140°C	Hot water, steam (max pressure 2.5 bar) Eau chaude, vapeur (Pression de service max 2.5bar) <i>Acqua calda, vapore (pressione max 2.5 bar)</i>

COMPONENTS / COMPOSANTS / COMPONENTI

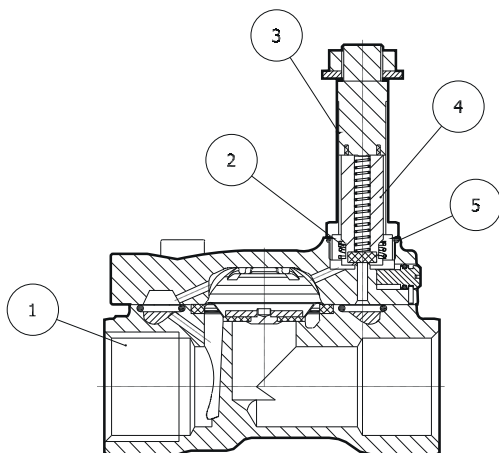

N.	DESCRIPTION / DESCRIPTION / DESCRIZIONE	MATERIAL / MATIÈRE / MATERIALE
1	Body / Corps / Corpo	Brass / Laiton / Ottone
2	Springs / Ressort / Molle	Stainless Steel / Acier inox / Acciaio inox
3	Armature tube / Tube de pilotage / Tubo guida	Stainless Steel / Acier inox / Acciaio inox
4	Core / Noyau / Nucleo	Stainless Steel / Acier inox / Acciaio inox
5	Seals / Joints / Guarnizioni	NBR - EPDM - FKM

2/2 NO / NO / NA

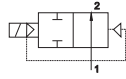

Code Code Codice	Seals Joints Guarnizioni	Thread size Filetage Filetto	Ø mm	Viscosity (Max cSt) Viscosité (Max cSt) Viscosità (Max cSt)	Kv m ³ /h	Power / Puissance Potenza		ΔP [bar]	
						IN	EXH	min	max
VQI1422010N	NBR	1/4	10	25	1.88	8	-	0.15	9.5
VQI1422010V	FKM					-	7.5	0.15	9.5
VQI1422010E	EPDM					-	11	0.15	9.5
VQI3822014N	NBR	3/8	14	25	3.32	8	-	0.15	9.5
VQI3822014V	FKM					-	7.5	0.15	9.5
VQI3822014E	EPDM					-	11	0.15	9.5
VQI1222014N	NBR	1/2	14	25	3.53	8	-	0.15	9.5
VQI1222014V	FKM					-	7.5	0.15	9.5
VQI1222014E	EPDM					-	11	0.15	9.5
VQI3422018N	NBR	3/4	18	25	5.56	8	-	0.15	9.5
VQI3422018V	FKM					-	7.5	0.15	9.5
VQI3422018E	EPDM					-	11	0.15	9.5
VQI1022025N	NBR	1	25	25	10.97	8	-	0.15	9.5
VQI1022025V	FKM					-	7.5	0.15	9.5
VQI1022025E	EPDM					-	11	0.15	9.5

Valves / Valves / Valvole

INDIRECT ACTING SOLENOID VALVES / ELECTROVANNES A COMMANDE INDIRECTE / ELETTROVALVOLE AD AZIONAMENTO INDIRETTO

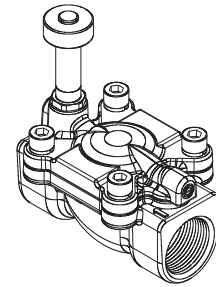
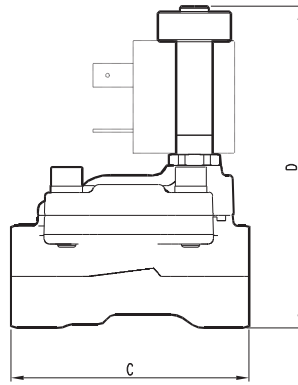
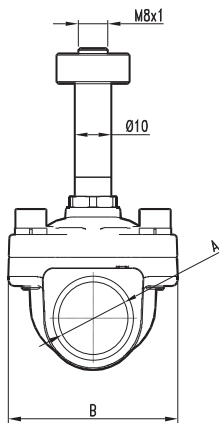

Size / Taille / Taglia	A	B	C	D
1/4"	G 1/4	35.2	55.5	76.6
3/8"	G 3/8	46.4	65.3	84.2
1/2"	G 1/2	46.4	65.3	84.2
3/4"	G 3/4	56.7	81	95
1"	G 1	65	95	101.1

2/2 NO WITH MANUAL OVERRIDE AND REGULATING PIN / 2/2 NO AVEC COMMANDE MANUELLE ET GOUPILLE DE REGLAGE
 2/2 NA CON COMANDO MANUALE E SPILLO DI REGOLAZIONE

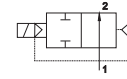

Code Code Codice	Seals Joints Guarnizioni	Thread size Filetage Filetto	Ø mm	Viscosity (Max cSt) Viscosité (Max cSt) Viscosità (Max cSt)	Kv m ³ /h	Power / Puissance Potenza		ΔP [bar]	
						IN	EXH	min	max
VQI3422018N1	NBR	3/4	18	25	5.56	8	-	0.15	9.5
VQI3422018V1	FKM					-	7.5	0.15	9.5
VQI3422018E1	EPDM					-	11	0.15	9.5
VQI1022025N1	NBR	1	25	25	10.97	8	-	0.15	9.5
VQI1022025V1	FKM					-	7.5	0.15	9.5
VQI1022025E1	EPDM					-	11	0.15	9.5

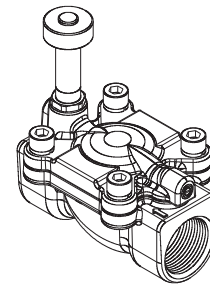
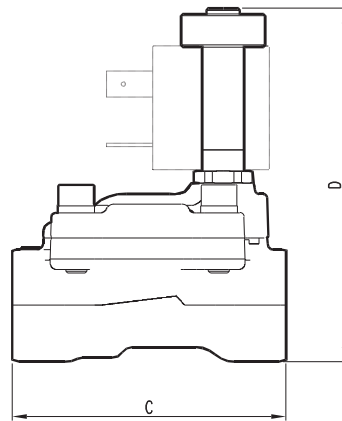
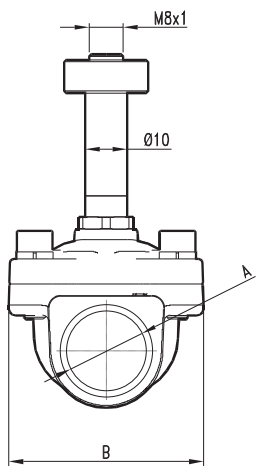

Size / Taille / Taglia	A	B	C	D
1/4"	G 1/4	35.2	55.5	76.6
3/8"	G 3/8	46.4	65.3	84.2
1/2"	G 1/2	46.4	65.3	84.2
3/4"	G 3/4	56.7	81	95
1"	G 1	65	95	101.1

2/2 NC WITH MANUAL OVERRIDE / 2/2 NF AVEC COMMANDE MANUELLE / 2/2 NC CON COMANDO MANUALE

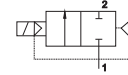

Code Code Codice	Seals Joints Guarnizioni	Thread size Filetage Filetto	Ø mm	Viscosity (Max cSt) Viscosité (Max cSt) Viscosità (Max cSt)	Kv m ³ /h	Power / Puissance Potenza		ΔP [bar]	
						DC (W)	AC (VA)	min	max
VQI1422C10N	NBR	1/4	10	25	1.88	6.5	-	0.15	11.2
VQI1422C10V	FKM					8	-	0.15	25
VQI1422C10E	EPDM					-	7.5	0.15	13.8
VQI3822C14N	NBR	3/8	14	25	3.32	6.5	-	0.15	11.2
VQI3822C14V	FKM					8	-	0.15	25
VQI3822C14E	EPDM					-	7.5	0.15	13.8
VQI1222C14N	NBR	1/2	14	25	3.53	6.5	-	0.15	11.2
VQI1222C14V	FKM					8	-	0.15	25
VQI1222C14E	EPDM					-	7.5	0.15	13.8
VQI3422C18N	NBR	3/4	18	25	5.56	6.5	-	0.15	11.2
VQI3422C18V	FKM					8	-	0.15	25
VQI3422C18E	EPDM					-	7.5	0.15	13.8
VQI1022C25N	NBR	1	25	25	10.97	6.5	-	0.15	11.2
VQI1022C25V	FKM					8	-	0.15	25
VQI1022C25E	EPDM					-	7.5	0.15	13.8
						-	11	0.15	25

Valves / Valves / Valvole

INDIRECT ACTING SOLENOID VALVES / ELECTROVANNES A COMMANDE INDIRECTE / ELETTROVALVOLE AD AZIONAMENTO INDIRETTO

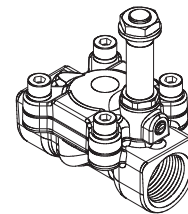
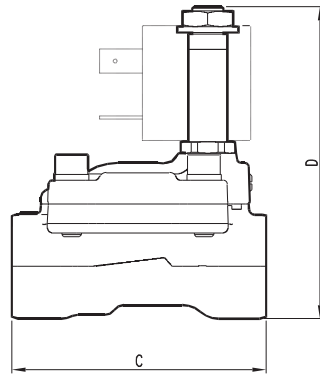
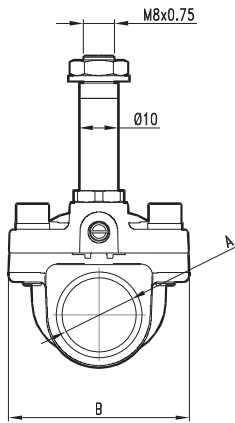

Size / Taille / Taglia	A	B	C	D
1/4"	G 1/4	35.2	55.5	72.5
3/8"	G 3/8	46.4	65.3	80.1
1/2"	G 1/2	46.4	65.3	80.1
3/4"	G 3/4	56.7	81	90.9
1"	G 1	65	95	97

2/2 NC WITH MANUAL OVERRIDE AND REGULATING PIN / 2/2 NF AVEC COMMANDE MANUELLE ET GOUPILLE DE REGLAGE
 2/2 NC CON COMANDO MANUALE E SPILLO DI REGOLAZIONE

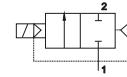

Code Code Codice	Seals Joints Guarnizioni	Thread size Filetage Filetto	Ø mm	Viscosity (Max cSt) Viscosité (Max cSt) Viscosità (Max cSt)	Kv m ³ /h	Power / Puissance Potenza		ΔP [bar]	
						DC (W)	AC (VA)	min	max
VQI3422C18N1	NBR	3/4	18	25	5.56	6.5	-	0.15	11.2
VQI3422C18V1	FKM					8	-	0.15	25
VQI3422C18E1	EPDM					-	7.5	0.15	13.8
VQI1022C25N1	NBR	1	25	25	10.97	6.5	-	0.15	11.2
VQI1022C25V1	FKM					8	-	0.15	25
VQI1022C25E1	EPDM					-	7.5	0.15	13.8
						-	11	0.15	25

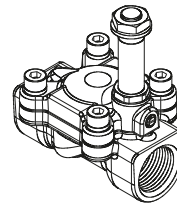
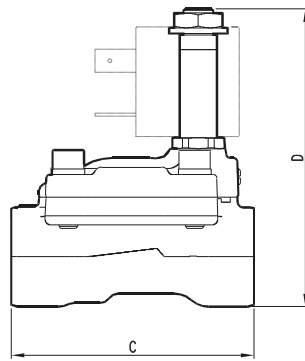
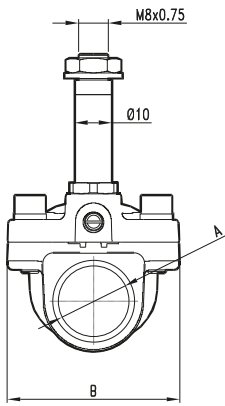

Size / Taille / Taglia	A	B	C	D
1/4"	G 1/4	35.2	55.5	72.5
3/8"	G 3/8	46.4	65.3	80.1
1/2"	G 1/2	46.4	65.3	80.1
3/4"	G 3/4	56.7	81	90.9
1"	G 1	65	95	97

KIT REPAIR SEALS
 KIT DE REPARATION JOINTS
 KIT RIPARAZIONE GUARNIZIONI



CODE	Seals Joints Guarnizioni	Size Taille Taglia
KZ642200	NBR	1/4
KZ643200	FKM	1/4
KZ645200	EPDM	1/4
KZ642312	NBR	3/8 - 1/2 Ø12
KZ643312	FKM	3/8 - 1/2 Ø12
KZ645312	EPDM	3/8 - 1/2 Ø12
KZ642314	NBR	3/8 - 1/2 Ø14
KZ643314	FKM	3/8 - 1/2 Ø14
KZ645314	EPDM	3/8 - 1/2 Ø14
KZ642400	NBR	3/4
KZ643400	FKM	3/4
KZ645400	EPDM	3/4
KZ642500	NBR	1"
KZ643500	FKM	1"
KZ645500	EPDM	1"

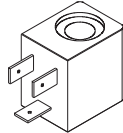
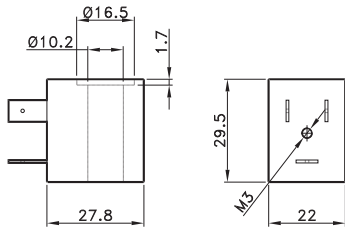

COILS 22 mm
BOBINE 22 mm
 BOBINE 22 mm

CODE	Power / Absorption / Assorbimento	
	Tension Tension Tensione	Power Puissance Potenza
BO4051012	12 V DC	6,5 W
BO4051024	24 V DC	6,5 W
BO4052024	24 V AC	7,5 VA
BO4052110	110 V AC	7,5 VA
BO4052220	220 V AC	7,5 VA

TECHNICAL SPECIFICATIONS
CARACTERISTIQUES TECHNIQUES
 CARATTERISTICHE TECNICHE

Tension tolerance / Tolérance tension / Tolleranza di tensione	+10%
Protection with connector / Protection avec connecteur / Protezione con connettore	IP65
Max working temperature / Température max d'utilisation / Temperatura max di esercizio	+ 50°C
Duty cycle / Temps d'enclenchement / Inserimento	ED 100%

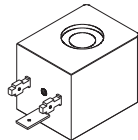
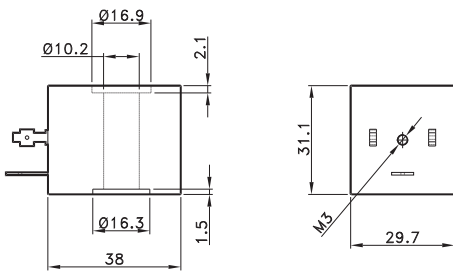

COILS 30 mm
BOBINE 30 mm
 BOBINE 30 mm

CODE	Power / Absorption / Assorbimento	
	Tension Tension Tensione	Power Puissance Potenza
BO4061012	12 V DC	8 W
BO4061024	24 V DC	8 W
BO4062024	24 V AC	11 VA
BO4062110	110 V AC	11 VA
BO4062220	220 V AC	11 VA

TECHNICAL SPECIFICATIONS
CARACTERISTIQUES TECHNIQUES
 CARATTERISTICHE TECNICHE

Tension tolerance / Tolérance tension / Tolleranza di tensione	+10%
Protection with connector / Protection avec connecteur / Protezione con connettore	IP65
Max working temperature / Température max d'utilisation / Temperatura max di esercizio	+ 50°C
Duty cycle / Temps d'enclenchement / Inserimento	ED 100%

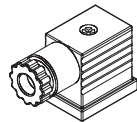
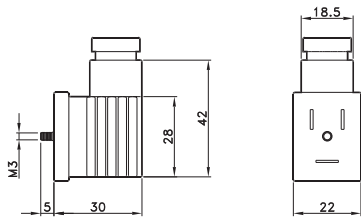

CONNECTORS 22 mm
CONNECTEUR 22 mm
 CONNETTORI 22 mm

CODE
AR40696

Cable diameter / **Diamètre du câble** / Diametro cavo
 6÷8 mm (22mm)
 8÷11mm (30mm)

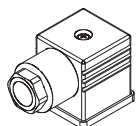
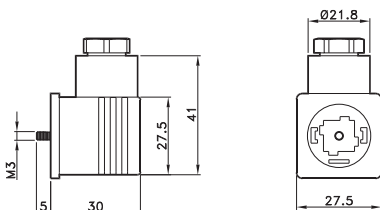

CONNECTORS 30 mm
CONNECTEUR 30 mm
 CONNETTORI 30 mm

CODE
VX0027

Cable diameter / **Diamètre du câble** / Diametro cavo
 6÷8 mm (22mm)
 8÷11mm (30mm)