

CX series stainless steel cylinders, have been designed respecting ISO 15552 norm. They are entirely made in stainless steel and their usage is particularly suitable in harsh atmospheres, like the naval, pharmaceutical and food industry. Bores are between Ø32 to 125 mm.

Le vérin série CX répond exactement à la norme ISO 15552.
Il est prévu pour être utilisé dans des ambiances spéciales: pharmaceutique, navale, alimentaire. Les tailles disponibles vont du 32 au 125 mm.

cilindri della serie CX sono stati realizzati rispettando la normativa ISO 15552.
Sono interamente realizzati in acciaio inox e sono particolarmente adatti all'utilizzo in ambienti difficili come: navale, farmaceutico, alimentare. Gli alesaggi sono compresi tra Ø32 e 125 mm.

ORDERING CODE / CODIFICATION / CHIAVE DI CODIFICA

C X 0 0 1 0 0 0 0 0 0

Stroke / Course / Corsa

Ø cylinder / Ø vérin / Ø cilindro

VERSION / VERSION / VERSIONE

- 01** Double acting cushioned magnetic / **Double effet amorti magnétique** / Doppio effetto ammortizzato magnetico
- 03** Through rod cushioned magnetic / **Tige traversante amorti magnétique** / Stelo passante ammortizzato magnetico
- 16** All stainless steel AISI 316, double acting cushioned magnetic / **Tout en acier inoxydable AISI 316, double effet amorti magnétique** / Tutto in acciaio inox AISI 316, doppio effetto ammortizzato magnetico
- 17** All stainless steel AISI 316, through rod cushioned magnetic / **Tout en acier inoxydable AISI 316, tige traversante amorti magnétique** / Tutto in acciaio inox AISI 316, stelo passante ammortizzato magnetico

SEALS / JOINTS / GUARNIZIONI

- 1** Standard / **Standard** / Standard (-20°C + 80°C)
- 3** High temperature / **Haute température** / Alta temperatura (-10°C + 150°C)
- 4** Heavy use / **Utilisation lourde** / Uso pesante (-20°C + 80°C)
- 8** Low temperature / **Basse température** / Bassa temperatura (-40°C + 80°C)



On request Atex version:
Sur demande version Atex:
 Su richiesta versione Atex:
 Ex II 2G Ex h II c T5 Gb
 Ex II 2D Ex h III c T100°C Db

TECHNICAL DATA / DONNÉES TECHNIQUES / DATI TECNICI

Sizes / Alésage / Alesaggi	Ø32-40-50-63-80-100-125
Standard strokes / Course standard / Corse standard	mm 25-50-80- 100-125-160-200-250-320-350-400-500-600-700-800-900-1000
Fluid / Fluide / Fluido	Lubricated or non lubricated air / Air avec ou sans lubrification / Aria con o senza lubrificazione
Operating temperature range / Température d'utilisation / Temperatura di esercizio	(-20°C + 80°C) (-10°C + 150°C) (-40°C + 80°C)
Max operating pressure / Pression max d'utilisation / Pressione massima di esercizio	10 bar
Force / Force / Forze sviluppate	Technical informations page / Page informations techniques / Pagina dati tecnici
Air consumption / Consommation d'air / Consumo aria	Technical informations page / Page informations techniques / Pagina dati tecnici

COMPONENTS / COMPOSANTS / COMPONENTI

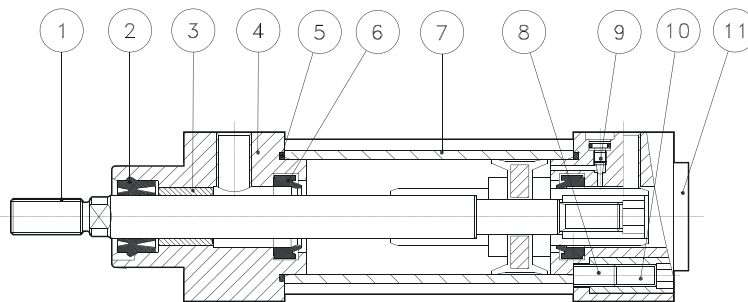

N.	DESCRIPTION / DESCRIPTION / DESCRIZIONE	MATERIAL / MATIÈRE / MATERIALE
1	rod / tige / stelo	stainless steel AISI 316 / acier inox 316 / acciaio inox 316
2	rod seal / joints tige / guarnizione stelo	polyurethane / polyuréthane / poliuretano
3	guide bush / bague guidage / bussola guida	bronze / bronze / bronzo
4	front cap / nez avant / testata anteriore	stainless steel AISI 304 / acier AISI 304 / acciaio AISI 304
5	o-ring / joint torique	NBR
6	cushion seal / joint d'amortissement / guarnizione ammortizzo	polyurethane / polyuréthane / poliuretano
7	tube / tube / tube	stainless steel AISI 304 / acier AISI 304 / acciaio inox 304
8	tie rod / tirant / tirante	stainless steel AISI316 / acier inox 316 / acciaio inox 316
9	regulator cushion screw / vis reg.amortis. / vite reg. ammortizzo	stainless steel AISI 316 / acier inox 316 / acciaio inox 316
10	fixing cap screw / vis serrage nez / vite serraggio testata	stainless steel AISI 316 / acier inox 316 / acciaio inox 316
11	rear cap / fond arrière / testata posteriore	stainless steel AISI 304 / acier AISI 304 / acciaio inox 304

Double acting magnetic cushioned
Double effet magnétique amorti
 Doppio effetto magnetico ammortizzato

CODE: CX011.Ø.mm

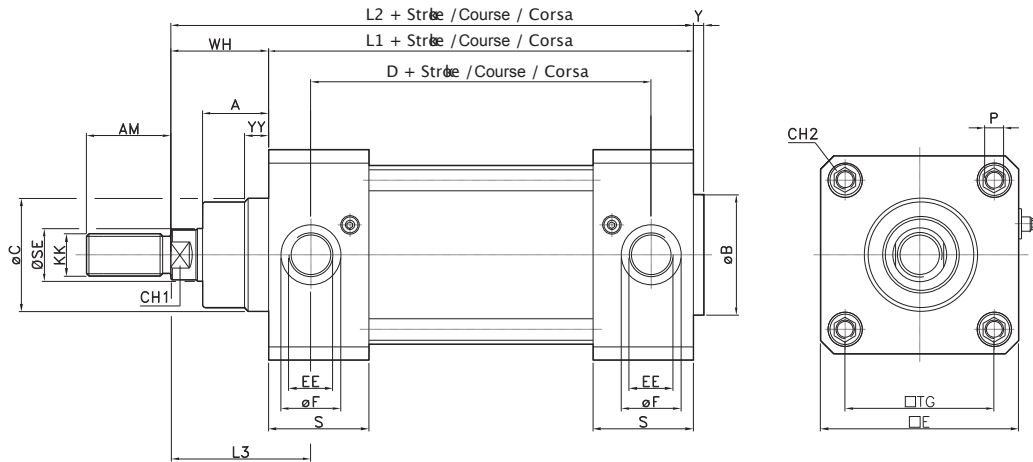
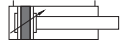

Ø	A	AM	B	C	D	E	EE	F	Y	YY	KK	L1	L2	L3	P	S	SE	TG	WH	CH1	CH2
32	18	22	30	30	67	50	G1/8"	16	4	9	M10x1.25	94	121	39.5	M6	30.8	12	32.5	26	10	6
40	22	24	35	35	77	55	G1/4"	19	4	9	M12x1.25	105	135	44	M6	33	16	38	30	13	6
50	25.5	32	40	40	78	65	G1/4"	19	4	9	M16x1.5	106	143	51	M8	33.7	20	46.5	37	16	8
63	25	32	45	45	89	75	G3/8"	22.7	4	9	M16x1.5	121	158	53	M8	38	20	56.5	37	16	8
80	35	40	45	45	96	95	G3/8"	22.7	4	9	M20x1.5	128	174	62	M10	40	25	72	46	21	10
100	38	40	55	55	102	110	G1/2"	28	4	9	M20x1.5	138	189	69	M10	43.5	25	89	51	21	10
125	46	54	60	60	124	139	G1/2"	28	6	10	M27x2	160	225	83	M12	53	32	110	65	27	12

Double acting magnetic through rod
Double effet magnétique tige traversante
 Doppio effetto magnetico stelo passante

CODE: CX031.Ø.mm

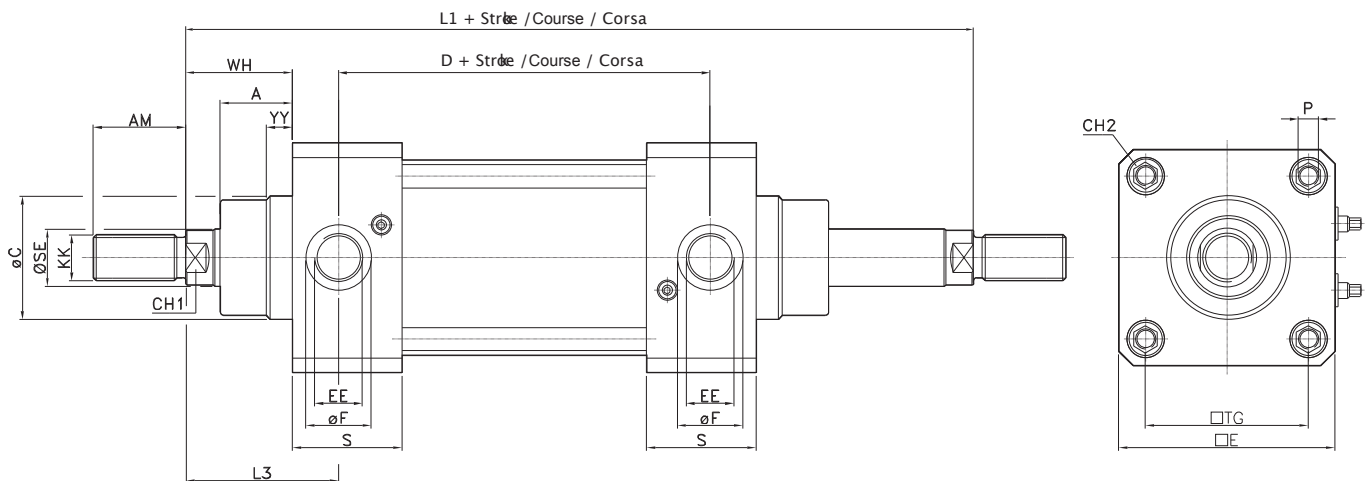
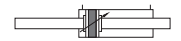

Ø	A	AM	C	D	E	EE	F	YY	KK	L1	L3	P	S	SE	TG	WH	CH1	CH2
32	18	22	30	67	50	G1/8"	16	9	M10x1.25	146	39.5	M6	30.8	12	32.5	26	10	6
40	22	24	35	77	55	G1/4"	19	9	M12x1.25	165	44	M6	33	16	38	30	13	6
50	25.5	32	40	78	65	G1/4"	19	9	M16x1.5	180	51	M8	33.7	20	46.5	37	16	8
63	25	32	45	89	75	G3/8"	22.7	9	M16x1.5	195	53	M8	38	20	56.5	37	16	8
80	35	40	45	96	95	G3/8"	22.7	9	M20x1.5	220	62	M10	40	25	72	46	21	10
100	38	40	55	102	110	G1/2"	28	9	M20x1.5	240	69	M10	43.5	25	89	51	21	10
125	46	54	60	124	139	G1/2"	28	11	M27x2	290	83	M12	53.2	32	110	65	28	12

MOUNTING PARTS / ACCESSOIRES DE MONTAGE / ACCESSORI DI FISSAGGIO

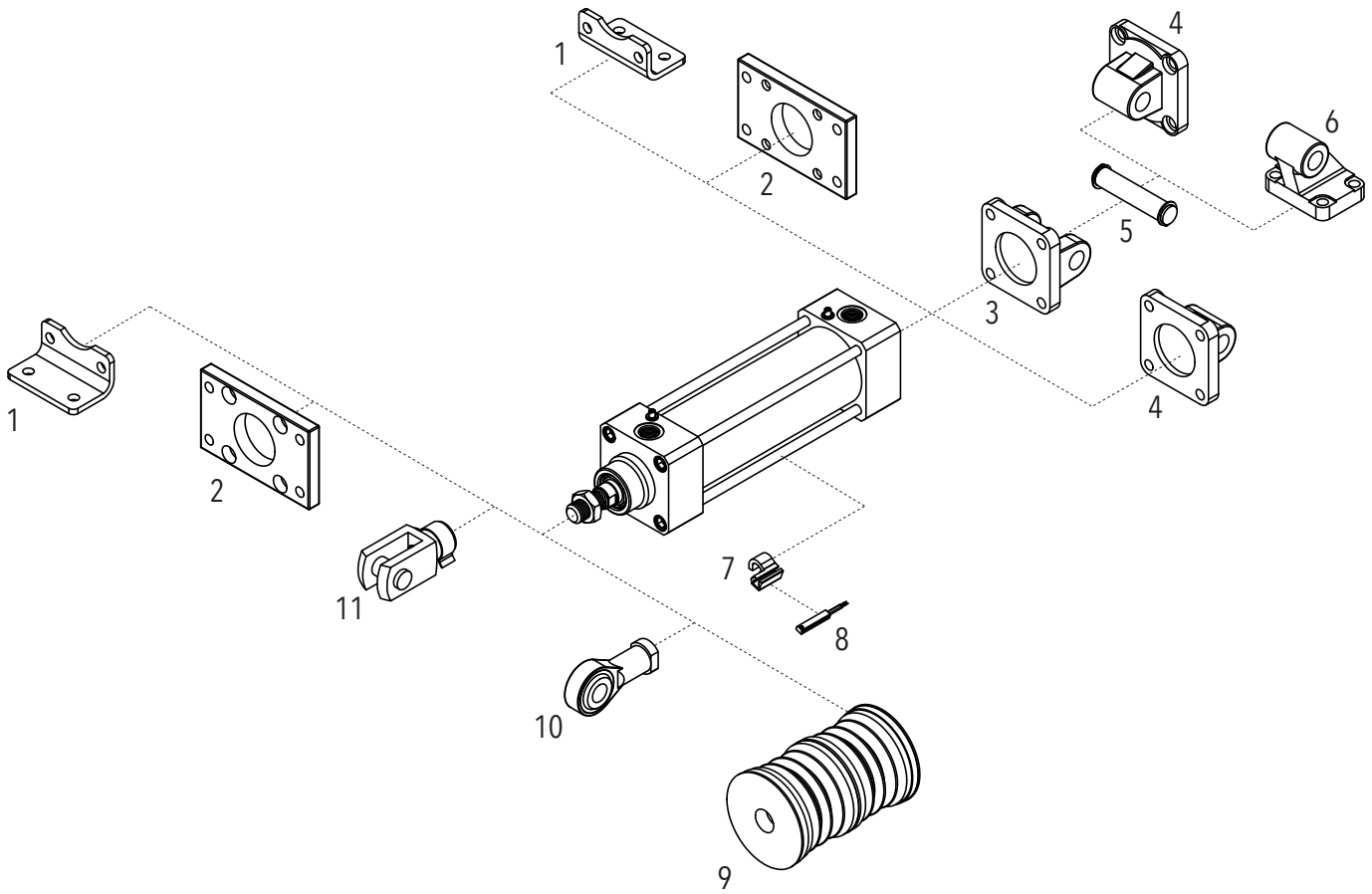

POS.	DESCRIPTION / DESCRIPTION / DESCRIZIONE	CODE
1	Pedestal / Equerre / Piedino	AR4169 Ø-V
2	Flange / Bride / Flangia	AR4168 Ø-V
3	Female hinge / Chape arrière femelle / Cerniera femmina	AR4164 Ø-V
4	Male hinge / Chape mâle arrière / Cerniera maschio	AR4165 Ø-V
5	Pivot for hinge / Axe chape arrière / Perno per cerniera	AR4167 Ø
6	Square joint / Articulation equerre / Articolazione a squadra	AR4166 Ø
7	Adaptor for switch / Adaptateur de capteur / Adattatore per sensore	AR4200 Ø
8	T switch / Capteur en T / Sensore a T	AR4023...
9	Rubber bellows / Soufflet / Soffietto	
10	Rod ends / Chape de tige rotulée / Testa a snodo	AR425...
11	Yoke / Fourche / Forcella	AR42...

PEDESTAL
EQUERRE
 PEDINO

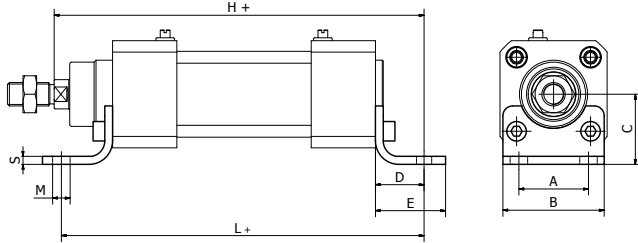
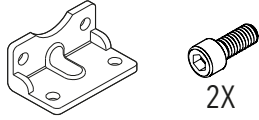

CODE AR4169 Ø-V **MATERIAL / MATIÈRE / MATERIALE** Stainless steel AISI 316 / **Inox AISI 316** / *Inox AISI 316*

Ø	A	B	C	D	E	H	L	M	S	weight (g)
032	32	45	32	24	35	144	142	7	4	60
040	36	52	36	28	36	163	161	9	4	72
050	45	65	45	32	47	175	170	9	5	160
063	50	75	50	32	45	190	185	9	5	180
080	63	95	63	41	55	215	210	12	6	370
100	75	115	71	41	57	230	220	14	6	432
125	90	140	90	45	70	270	250	16	8	

FLANGE
BRIDE
 FLANGIA

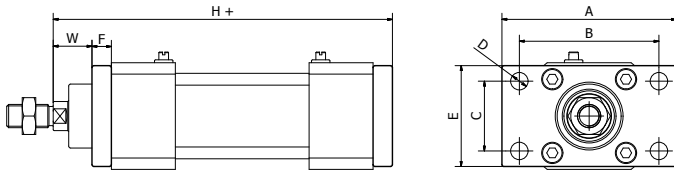
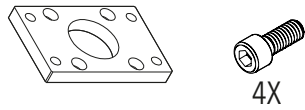

CODE AR4168 Ø-V **MATERIAL / MATIÈRE / MATERIALE** Stainless steel AISI 316 / **Inox AISI 316** / *Inox AISI 316*

Ø	A	B	C	D	E	F	H	W	weight (g)
032	80	64	32	7	45	10	130	16	192
040	90	72	36	9	52	10	145	20	250
050	110	90	45	9	65	12	155	25	482
063	120	100	50	9	75	12	170	25	626
080	150	126	63	12	95	16	190	30	1436
100	170	150	75	14	115	16	205	35	1994
125	205	180	90	16	140	20	245	45	

FEMALE HINGE
CHAPE ARRIERE
 CERNIERA FEMMINA

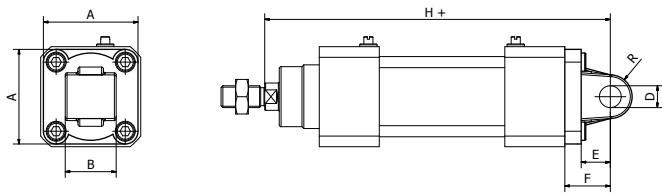
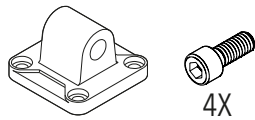

CODE AR4165 Ø-V **MATERIAL / MATIÈRE / MATERIALE** Stainless steel AISI 316 / **Inox AISI 316** / *Inox AISI 316*

Ø	A	B	D	E	F	H	R	weight (g)
032	45	26	10	13	22	142	10	176
040	52	28	12	16	25	160	12	274
050	65	32	12	16	27	170	12	368
063	75	40	16	21	32	190	16	682
080	95	50	16	22	36	210	16	1196
100	115	60	20	27	41	230	20	2100
125	140	70	25	30	50	275	25	3740

FEMALE HINGE
CHAPE ARRIERE
 CERNIERA FEMMINA

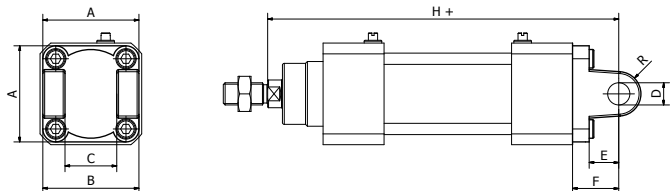
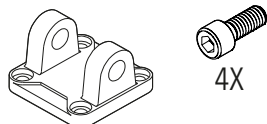

CODE AR4164 Ø-V **MATERIAL / MATIÈRE / MATERIALE** Stainless steel AISI 316 / **Inox AISI 316** / *Inox AISI 316*

Ø	A	B	C	D	E	F	H	R	weight (g)
032	45	45	26	10	13	22	142	10	138
040	52	52	28	12	16	25	160	12	230
050	65	60	32	12	16	27	170	12	338
063	75	70	40	16	21	32	190	16	540
080	95	90	50	16	22	36	210	16	1000
100	115	110	60	20	27	41	230	20	1700
125	140	130	70	25	30	50	275	25	3350

SQUARE JOINT
ARTICULATION ARRIERE D'EQUERRE
 ARTICOLAZIONE A SQUADRA

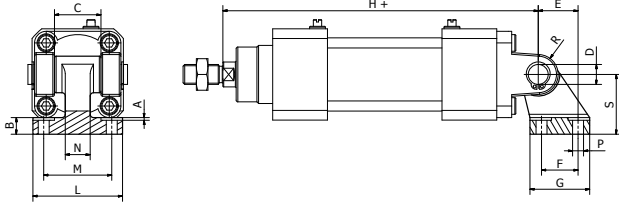
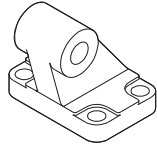

CODE MATERIAL / MATIÈRE / MATERIALE
AR4166 Ø Stainless steel AISI 316 /Inox AISI 316 / Inox AISI 316

Ø	A	B	C	D	E	F	G	H	L	M	N	P	R	S	weight (g)
032	1.6	8	26	10	21	18	31	142	51	38	10	6.6	10	32	158
040	1.6	10	28	12	24	22	35	160	54	41	15	6.6	12	36	238
050	1.6	12	32	12	33	30	45	170	65	50	16	9	12	45	418
063	1.6	14	40	16	37	35	50	190	67	52	16	9	16	50	526
080	2.5	14	50	16	47	40	60	210	86	66	20	11	16	63	1055
100	2.5	17	60	20	55	50	70	230	96	76	20	11	20	71	1510
125	3.2	20	70	25	70	60	90	275	124	94	30	14	25	90	3150

PIVOT FOR HINGE
AXE ARTICULATION ARRIERE FEMELLE
 PERNO PER CERNIERA

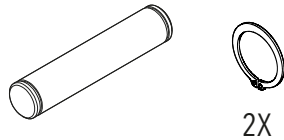

2X

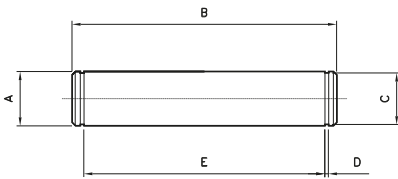

CODE MATERIAL / MATIÈRE / MATERIALE
AR4167 Ø Stainless steel AISI 316 /Inox AISI 316 / Inox AISI 316

Ø	A	B	C	D	E
032	10	53	9.6	1.1	46
040	12	60	11.5	1.1	53
050	12	68	11.5	1.1	61
063	16	78	15.2	1.1	71
080	16	98	15.2	1.1	91
100	20	118	19	1.3	111
125	25	139	23.9	1.3	132

ROD ENDS
CHAPE DE TIGE ROTULEE
 TESTA A SNODO

Material: Stainless steel AISI 316
 Matière: **Inox AISI 316**
 Materiale: **Inox AISI 316**

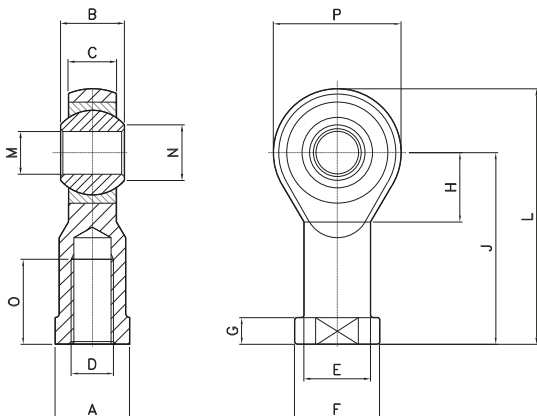
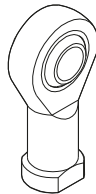

CODE Ø
AR4250 32
AR4251 40
AR4252 50-63
AR4253 80-100
AR4254 125

Ø	A	B	C	D	E	F	G	H	J	L	M	N	O	P
32	17	14	10.5	M10x1.25	15	19	6.5	15	43	57	10	12.9	20	28
40	19	16	12	M12x1.25	17.5	22	6.5	17	50	66	12	15.4	22	32
50-63	22	21	15	M16x1.5	22	27	8	23	64	85	16	19.3	28	42
80-100	30	25	18	M20x1.5	27.5	34	10	27	77	102	20	24.3	33	50
125	41	37	25	M27x2	40	50	15	36	110	145	30	34.8	51	70

YOKE WITH PIVOT
CHAPE DE TIGE AVEC AXE
 FORCELLA CON PERNO

Material: Stainless steel AISI 303
Matière: Inox AISI 303
 Materiale: Inox AISI 303

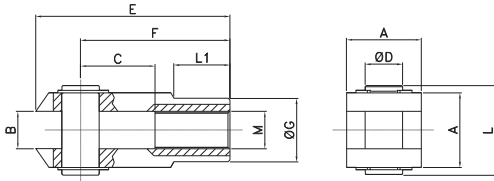
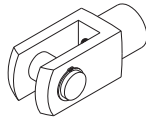

Complete of pivot and seeger
Chape + axe + circlips
 Completo di perno e seeger

CODE	Ø
AR4218	32
AR4219	40
AR4220	50-63
AR4221	80-100
AR4222	125

Ø	A	B	C	D	E	F	G	M	L	L1
32	20	10	20	10	52	40	18	M10x1.25	25	15
40	24	12	24	12	62	48	20	M12x1.25	30	18
50/63	32	16	32	16	83	64	26	M16x1.5	39	24
80/100	40	20	40	20	105	80	34	M20x1.5	48	30
125	55	30	54	30	148	110	48	M27x2	65	38

T SWITCH
CAPTEUR EN T
 SENSORE AT

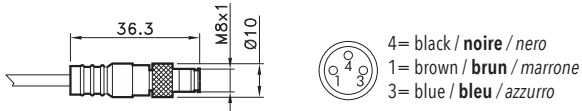
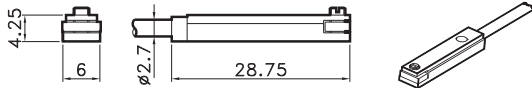

4= black / **noire** / nero
 1= brown / **brun** / marrone
 3= blue / **bleu** / azzurro

CODE	
AR4023010	REED (MT.2,5) / REED (MT.2,5) / REED (MT.2,5)
AR4023020	HALL (MT.2,5) / HALL (MT.2,5) / HALL (MT.2,5)
AR4023110	REED + M8 (CM 30) / REED + M8 / REED + M8 (CM 30)
AR4023120	HALL + M8 (CM 30) / HALL + M8 / HALL + M8 (CM 30)

For technical data see page 1.74
Pour les données techniques, voir page 1.74
 Per i dati tecnici vedere pag. 1.74

ADAPTOR FORT SWITCH
ADAPTATEUR CAPTEUR EN T
 ADATTATORE SENSORE AT

Material: Aluminium
Matière: Aluminium
 Materiale: Alluminio

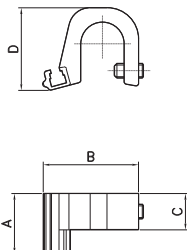
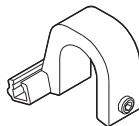

CODE	Ø
AR420032	32-40
AR420050	50-63
AR420080	80-100
AR4200125	125

Ø	A	B	C	D
32-40	25	30	15	20
50-63	25	35	15	26
80-100	25	38	15	30
125	25	40	15	35