

CIC introduce the new compact cylinder CP series with big dimensions.  
In all applications requiring great push force in small spaces, the new cylinder CP series is the correct answer.

**Le nouveau vérin série CP est compact avec de grands diamètres, il est utilisé pour de fortes poussées et des espaces réduits.**

CIC presenta i nuovi cilindri compatti di grandi dimensioni.  
In tutte le applicazioni ove sia necessario avere grande forza di spinta in ridotti spazi, il nuovo cilindro della serie CP, è la risposta giusta.

ORDERING CODE / CODIFICATION / CHIAVE DI CODIFICA

C P 0 0 1 0 0 0 0 0 0 -

- = Female stem / **Tige femelle** / Stelo femmina  
M = Male stem / **Tige mâle** / Stelo maschio

Stroke / **Course** / Corsa

Ø cylinder / **Ø vérin** / Ø cilindro

VERSION / **VERSION** / VERSIONE

- 01 = Double acting magnetic / **Double effet magnétique** / Doppio effetto magnetico
- 02 = Double acting non magnetic / **Double effet non magnétique** / Doppio effetto non magnetico
- 03 = Through rod-magnetic / **Tige traversante magnétique** / Stelo passante magnetico
- 04 = Through rod non magnetic / **Tige traversante non magnétique** / Stelo passante non magnetico



On request Atex version:  
**Sur demande version Atex:**  
Su richiesta versione Atex:  
Ex II 2G Ex h II c T6 Gb  
Ex II 2D Ex h III c T80°C Db

VERSION / **VERSION** / VERSIONE

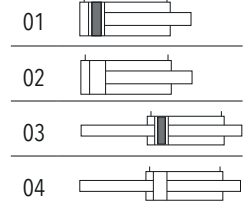

TECHNICAL DATA / **DONNÉES TECHNIQUES** / DATI TECNICI

Sizes / <b>Alésage</b> / Alesaggi	Ø125-160-200
Standard strokes / <b>Course standard</b> / Corse standard	mm 5-10-15-20-25-30-40-50-60-70-80-90-100-125-160-200-250
Fluid / <b>Fluide</b> / Fluido	Lubricated or non lubricated air / <b>Air lubrifié ou non lubrifié</b> / Aria con o senza lubrificazione
Operating temperature range / <b>Température d'utilisation</b> / Temperatura di esercizio	-20°C / +80°C
Max operating pressure / <b>Pression max d'utilisation</b> / Pressione massima di esercizio	10 bar
Force / <b>Force</b> / Forze sviluppate	Technical informations page / <b>Page informations techniques</b> / Pagina dati tecnici
Air consumption / <b>Consommation d'air</b> / Consumo aria	Technical informations page / <b>Page informations techniques</b> / Pagina dati tecnici

COMPONENTS / **COMPOSANTS** / COMPONENTI

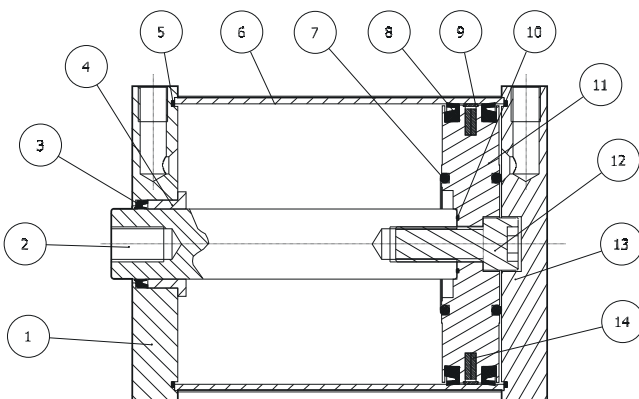

N.	DESCRIPTION / <b>DESCRIPTION</b> / DESCRIZIONE	MATERIAL / <b>MATIÈRE</b> / MATERIALE
1	cap / <b>nez avant</b> / testata anteriore	aluminium / <b>aluminium</b> / alluminio
2	rod / <b>tige</b> / stelo	steel C40 chromed / <b>C40 chromé</b> / C40 cromato
3	rod seal / <b>joint de tige</b> / guarnizione stelo	polyurethane / <b>polyuréthane</b> / poliuretano
4	guide bush / <b>bague guidage</b> / bussola guida	bronze / <b>bronze</b> / bronzo
5	o-ring / <b>joint torique</b>	NBR
6	tube / <b>tube</b> / tubo	aluminium / <b>aluminium</b> / alluminio
7	o-ring / <b>joint torique</b>	NBR
8	seal piston / <b>joint piston</b> / guarnizione pist.	polyurethane / <b>polyuréthane</b> / poliuretano
9	guide strip / <b>joint guidage</b> / fascia guida	PBT + PTFE
10	o-ring / <b>joint torique</b>	NBR
11	piston / <b>piston</b> / pistone	aluminium / <b>aluminium</b> / alluminio
12	piston screw / <b>vis piston</b> / vite pistone	steel / <b>acier</b> / acciaio
13	cap / <b>fond arrière</b> / testata posteriore	aluminium / <b>aluminium</b> / alluminio
14	magnet / <b>aimant</b> / magnete	plastroferrite

Double acting  
**Double effet**  
*Doppio effetto*

CODE: CP011.Ø.mm

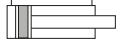

CODE: CP021.Ø.mm

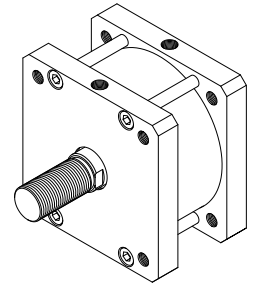
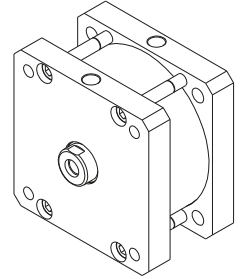
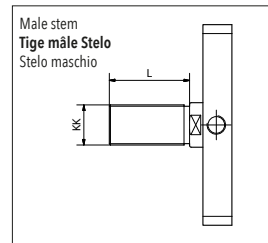
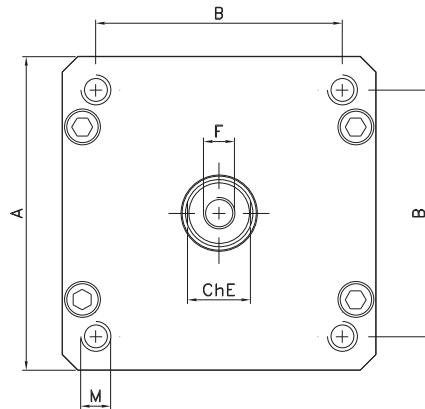
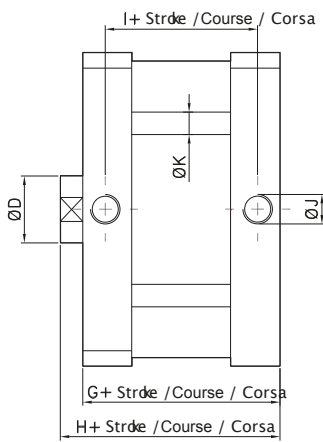
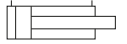

Ø	A	B	M	ØD	E	F	G	H	I	J	ØK	KK	L
125	140	110	M12	30	28	M14x25 ut.	78	88	58	G1/4"	10	M27x2	54
160	180	140	M16	40	36	M20x30 ut.	87	99	63	G3/8"	12	M36x2	72
200	220	175	M16	40	36	M20x30 ut.	87	99	63	G3/8"	14	M36x2	72

Through rod  
**Tige traversante**  
*Stelo passante*

CODE: CP031.Ø.mm

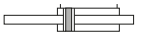

CODE: CP041.Ø.mm

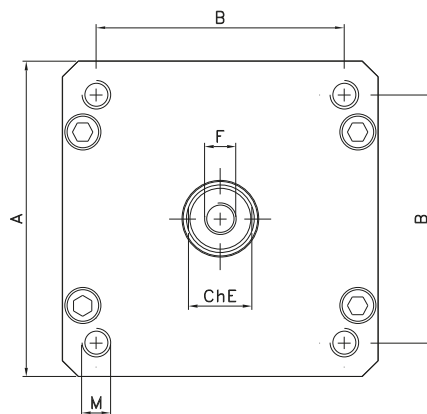
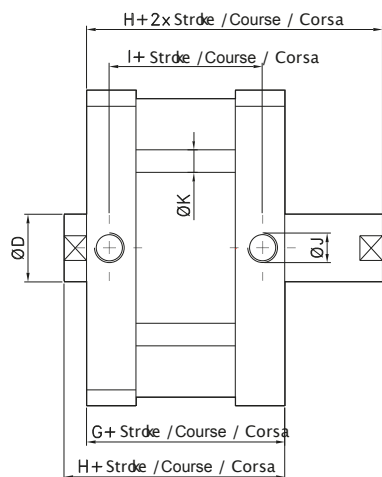

Ø	A	B	M	ØD	E	F	G	H	I	J	ØK
125	140	110	M12	30	28	M14x25 ut.	78	88	58	G1/4"	10
160	180	140	M16	40	36	M20x30 ut.	87	99	63	G3/8"	12
200	220	175	M16	40	36	M20x30 ut.	87	99	75	G3/8"	14

PEDESTAL  
**EQUERRE**  
 PIEDINO

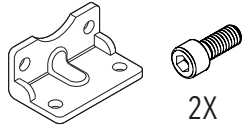

2X

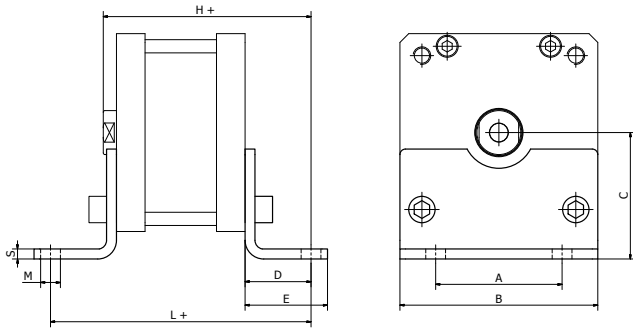

CODE MATERIAL / **MATIÈRE** / MATERIALE  
 AR4152 Ø -V Steel / **Acier** / Acciaio

Ø	A	B	C	D	E	H	L	M	S	weight (g)
125	90	140	90	45	70	133	168	16	8	1150
160	115	180	115	60	75	159	207	18	9	2000
200	135	220	135	70	100	169	227	22	12	3800

FLANGE  
**BRIDE**  
 FLANGIA

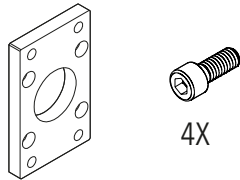

4X

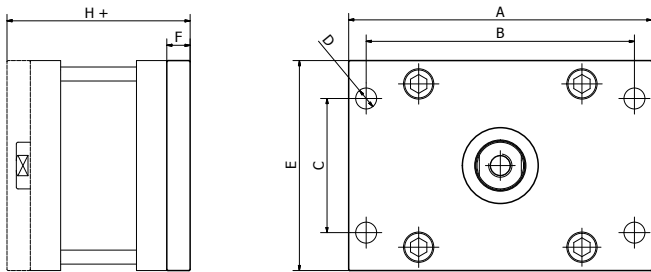

CODE MATERIAL / **MATIÈRE** / MATERIALE  
 AR4151 Ø -V Steel / **Acier** / Acciaio

Ø	A	B	C	D	E	F	H	weight (g)
125	205	180	90	16	140	20	118	3750
160	260	230	115	18	180	20	127	6362
200	300	270	135	22	220	25	137	11368

MALE HINGE  
**CHAPE MALE ARRIERE**  
 CERNIERA MASCHIO

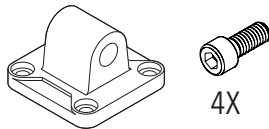

4X

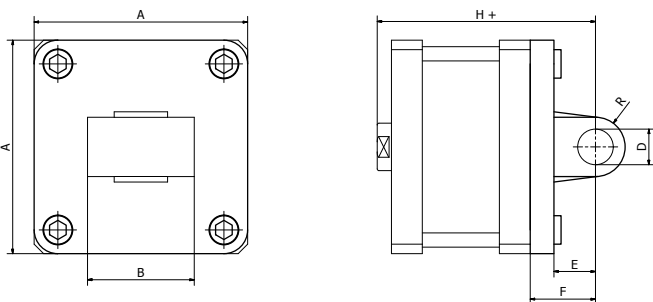

CODE MATERIAL / **MATIÈRE** / MATERIALE  
 AR4149 Ø -V Aluminium / **Aluminium** / Alluminio  
 AR4186 Ø -V Steel / **Acier** / Acciaio

Ø	A	B	D	E	F	H	R	weight (g)	weight (g)
125	140	70	25	30	50	138	25	1264	3740
160	180	90	30	35	55	154	25	1846	5890
200	220	90	30	35	60	159	25	2950	8470

FEMALE HINGE  
**CHAPE ARRIERE FEMELLE**  
 CERNIERA FEMMINA

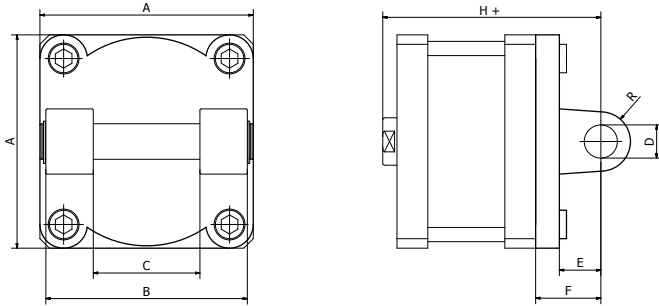
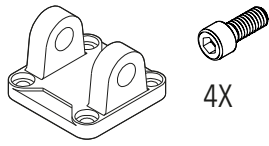

CODE	MATERIAL / MATIÈRE / MATERIALE
AR4147 Ø-V	Aluminium / <b>Aluminium</b> / Alluminio
AR4184 Ø-V	Steel / <b>Acier</b> / Acciaio

Ø	A	B	C	D	E	F	H	R	weight (g)	weight (g)
125	140	130	70	25	30	50	138	25	1180	3350
160	180	170	90	30	35	55	154	25	1780	5750
200	220	170	90	30	35	60	159	25	2900	8900

SQUARE JOINT  
**ARTICULATION ARRIERE D EQUERRE**  
 ARTICOLAZIONE A SQUADRA

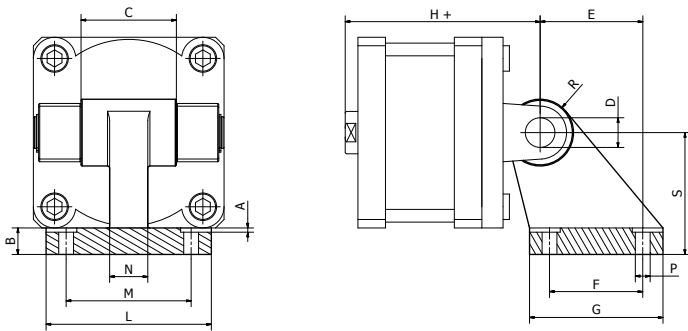
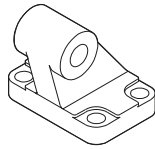

CODE	MATERIAL / MATIÈRE / MATERIALE
AR4156 Ø	Aluminium / <b>Aluminium</b> / Alluminio

Ø	A	B	C	D	E	F	G	H	L	M	N	P	R	S	(g)
125	3.2	20	70	25	70	60	90	138	124	94	30	14	25	90	826
160	4	25	90	30	97	88	126	154	156	118	36	14	25	115	2600
200	4	30	90	30	105	90	130	159	162	122	40	18	25	135	3250

PIVOT FOR FEMALE HINGE  
**AXE POUR CHAPE FEMELLE**  
 PERNO PER CERNIERA FEMMINA

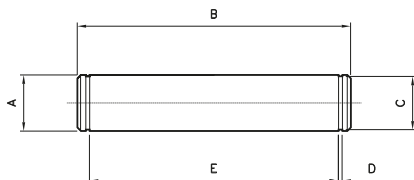
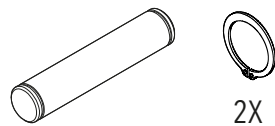

CODE	MATERIAL / MATIÈRE / MATERIALE
AR4150 Ø	Steel / <b>Acier</b> / Acciaio

Ø	A	B	C	D	E	weight (g)
125	25	139	23.9	1.3	132	530
160	30	178	28.6	1.6	171.5	978
200	30	178	28.6	1.6	171.5	978

YOKE WITH PIVOT  
**FOURCHE AVEC TIGE**  
 FORCELLA CON PERNO

Material: Steel  
**Matière: Acier**  
 Materiale: Acciaio

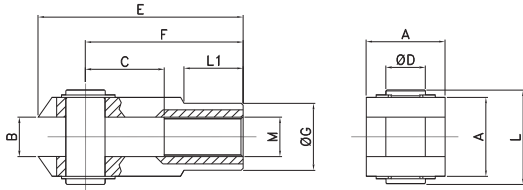
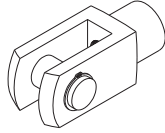

CODE	Ø
AR40678	125
AR40679	160-200

Ø	A	B	C	D	E	F	G	M	L	L1
125	55	30	54	30	148	110	48	M27x2	65	38
160/200	70	35	72	35	188	144	60	M36x2	84	40

ROD ENDS  
**CHAPE DE TIGE ROTULEE**  
 TESTA A SNODO

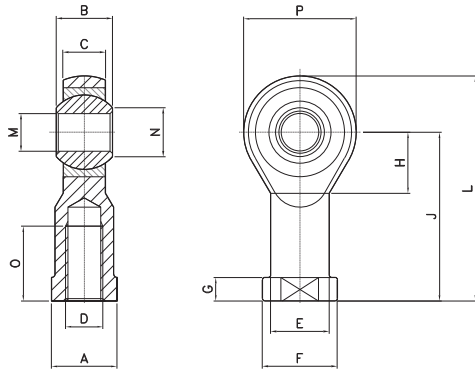
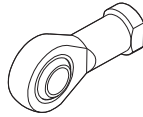

CODE	Ø
AR40667	125
AR40669	160-200

Ø	A	B	C	D	E	F	G	H	J	L	M	N	O	P
125	41	37	25	M27x2	40	50	15	36	110	145	30	34.8	51	70
160-200	50	43	28	M36x2	46	58	17	41	125	165	35	37.7	56	80

T SWITCH  
**CAPTEUR EN T**  
 SENSORE A T

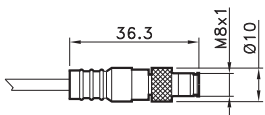
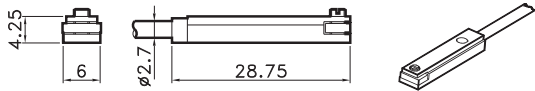

4= black / **noire** / nero  
 1= brown / **brun** / marrone  
 3= blue / **bleu** / azzurro

CODE	
AR4023010	REED (MT.2,5) / <b>REED (MT.2,5)</b> / REED (MT.2,5)
AR4023020	HALL (MT.2,5) / <b>HALL (MT.2,5)</b> / HALL (MT.2,5)
AR4023110	REED + M8 (CM 30) / <b>REED + M8</b> / REED + M8 (CM 30)
AR4023120	HALL + M8 (CM 30) / <b>HALL + M8</b> / HALL + M8 (CM 30)

For technical data see page 1.74

**Pour les données techniques, voir page 1.74**

Per i dati tecnici vedere pag. 1.74

ADAPTOR FOR 'T' SWITCH  
**ADAPTATEUR DE CAPTEUR EN "T"**  
 ADATTATORE SENSORE A "T"

Material: Aluminium  
**Matière: Aluminium**  
 Materiale: Alluminio

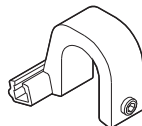

CODE	Ø
AR4200125	125-160-200