

Cartridge cylinders of the series CH have extremely reduced dimensions, a threaded body which allows to be installed in any part of the machine and, thanks to the use of an OR, it is possible to obtain the air sealing between threaded hole and cylinder.

Les minivérins série CH, sont des vérins de dimensions très réduites, son corps fileté lui permet d'être monté en tout point dans la machine avec l'utilisation d'un joint, il est possible d'obtenir l'étanchéité à l'air entre le trou fileté et le vérin.

I cilindri a cartuccia della serie CH, hanno dimensioni estremamente contenute, un corpo filettato che gli permette di essere montato in qualsiasi punto della macchina e, con l'utilizzo di un o-ring, è possibile ottenere la tenuta aria tra il foro filettato e il cilindro stesso.

ORDERING CODE / CODIFICATION / CHIAVE DI CODIFICA

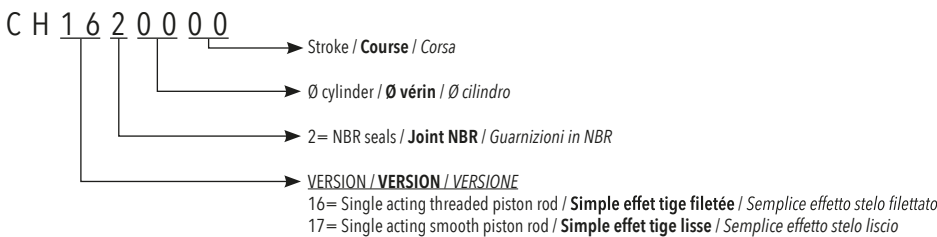

VERSION / VERSION / VERSIONE

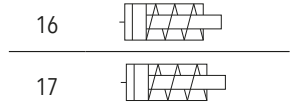

STANDARD STROKES / COURSE STANDARD / CORSE STANDARD

Single acting / Simple effet / Semplice effetto

- Ø6 mm 05-10-15
- Ø10 mm 05-10-15
- Ø16 mm 05-10-15

TECHNICAL DATA / DONNÉES TECHNIQUES / DATI TECNICI

Fluid / Fluide / Fluido	Lubricated or non lubricated air / Air avec ou sans lubrification / Aria con o senza lubrificazione
Operating temperature range / Température d'utilisation / Temperatura di esercizio	-20°C / +80°C
Max operating pressure / Pression max d'utilisation / Pressione massima di esercizio	6 bar
Force / Force / Forze sviluppate	Technical informations page / Page informations techniques / Pagina dati tecnici
Air consumption / Consommation d'air / Consumo aria	Technical informations page / Page informations techniques / Pagina dati tecnici

POSSIBLE INSTALLATION / MONTAGE POSSIBLE / POSSIBILE MONTAGGIO

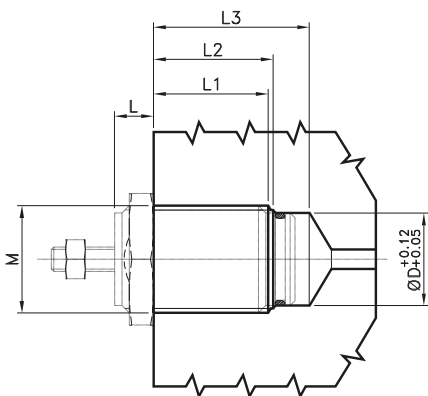

Dimensions for machining cylinder seat / Dimensions pour usinage siège du vérin / Dimensioni per la lavorazione sede cilindro

Ø	M	L / C			L1 / C			L2 / C			L3 / C			ØD
		5	10	15	5	10	15	5	10	15	5	10	15	
6	M10x1	5	5	5	10	17	24	12	19	26	16	24	31	8.5
10	M15x1.5	6	6	6	11	17	24	13	19	26	20	26	34	12
16	M22x1.5	7	7	7	15	20	25	17	21	27	26	31	36	19

Threaded rod
Tige filetée
 Stelo filettato

CODE: CH162.Ø.mm

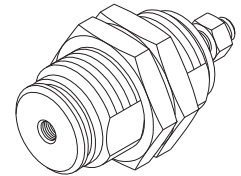
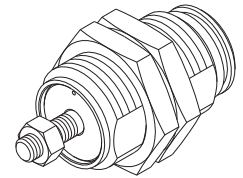
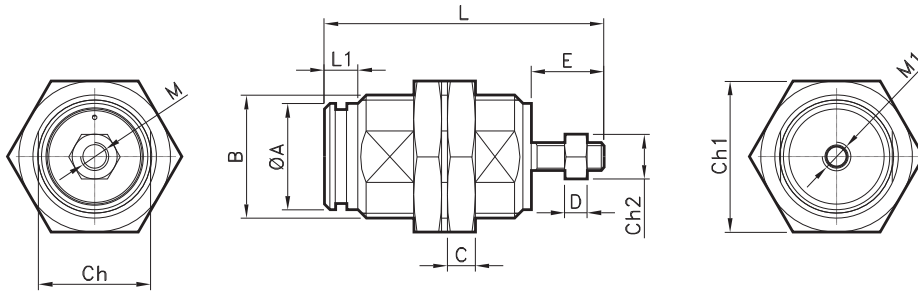
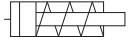

Ø	ØA	B	CH1	C	CH2	D	E	L(05 - 10 - 15)	L1	M	M1	CH
6	8.5	M10x1	14	3	5.5	2.4	8	27.5 - 34.5 - 41.5	5	M3	M5	9
10	12	M15x1.5	19	4	7	3.2	10.5	33.5 - 40 - 47	7	M4	M5	14
16	19	M22x1.5	27	5	8	4	13	40 - 45 - 50	6	M5	M5	20

Smooth rod
Tige lisse
 Stelo liscio

CODE: CH172.Ø.mm

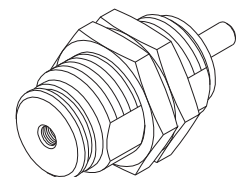
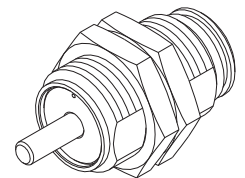
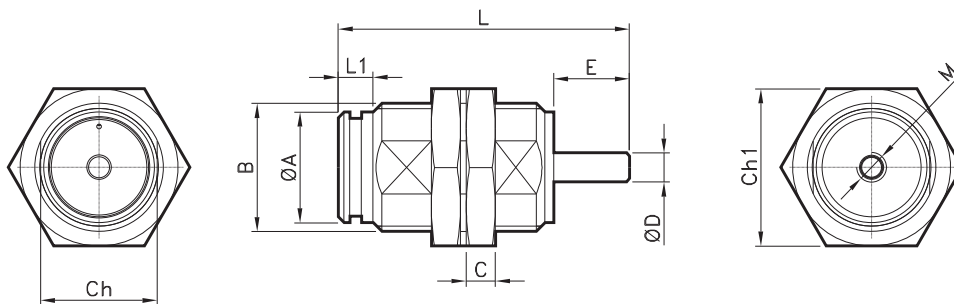

Ø	ØA	B	CH1	C	D	E	L(05 - 10 - 15)	L1	M	CH
6	8.5	M10x1	14	3	3	8	27.5 - 34.5 - 41.5	5	M5	9
10	12	M15x1.5	19	4	4	10.5	33.5 - 40 - 47	7	M5	14
16	19	M22x1.5	27	5	5	13	40 - 45 - 50	6	M5	20